

# New RRA

- Contact seals working independently of pressure
- Middle seal permanently pressure resistant and dimensionally stable, without sealing gap
- Compact casing for larger wheel diameter
- Low maintenance friction wheel drive

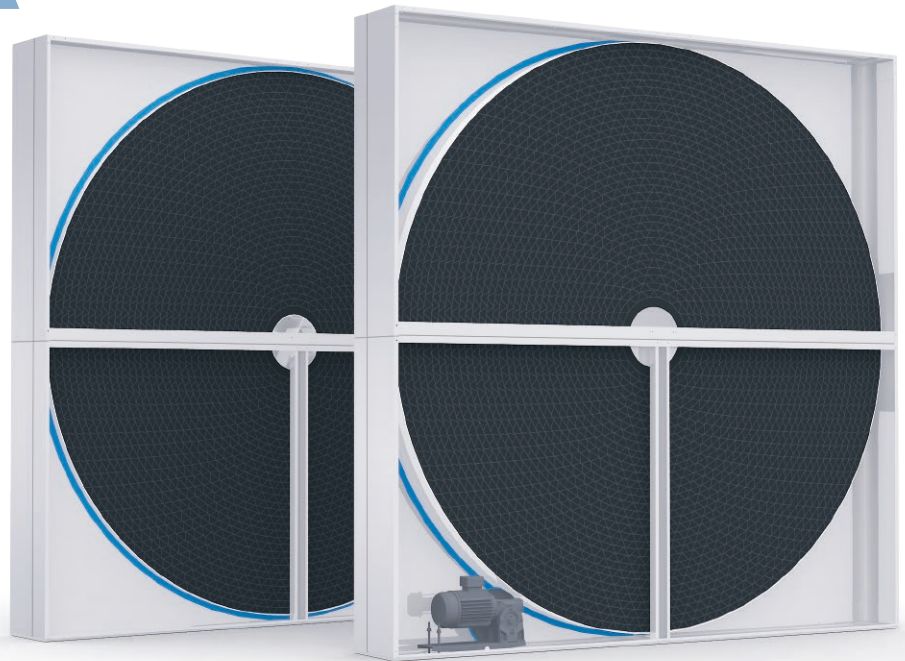

## The new Klingenburg casing with twin-contact sealing system and reduced leakage

With rotating seals which work against the particular pressure difference inside the AHU, plus an air separation practically without sealing gap, the RRA sets new standards in air tightness inside the Klingenburg rotor family.

Smaller distances between rotating accumulation mass and casing allow the configuration of larger wheel diameter than before – more efficiency at lower pressure drop. Available in undivided design up to casing dimensions of 2500 mm.

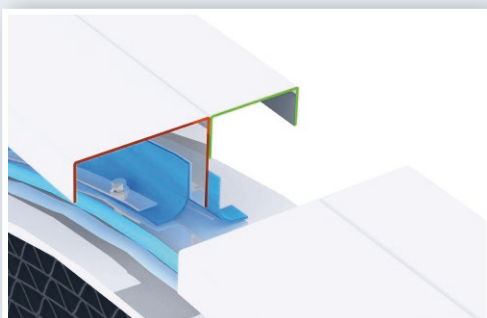

*Highest air tightness due to construction and new innovative twin-contact seal system*

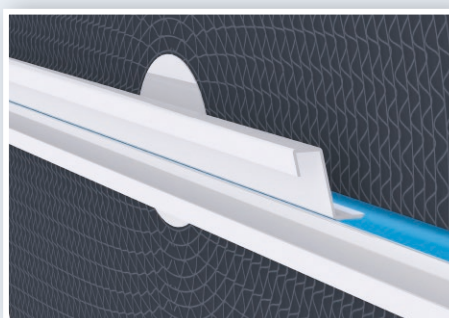

*Middle seal permanently pressure resistant and dimensionally stable, without sealing gap*

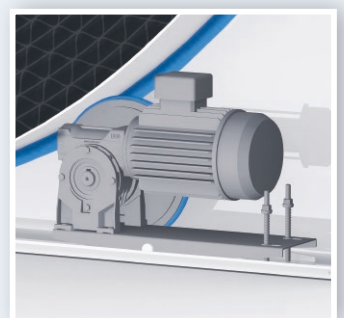

*Low maintenance friction wheel drive*